



SCOMES

Product model: FRS04A/AC690V/AC700V

Document number: 0ZT.198.126

Version : A - April 2024

Product name: Fuses for semiconductor equipment protection

Manufacturer:

Scomes Srl

Address:

Via Enrico Mattei 6/8

26823 Castiglione d'Adda (LO) – Italy

www.scomes.com

Index

1、 Scope of application and use.....	3
2、 Product model.....	4
3、 Shape and installation dimensions.....	4
4、 Tightening torque of connecting screw.....	5
5、 Main technical parameters.....	5
6、 Forearc time - expected current curve.....	6
7、 Service conditions.....	6
8、 Safe use and maintenance.....	13

1、 Scope of application and use

This series of semiconductor equipment protection fuse (hereinafter referred to as "fuse"), with the resistance to temperature shock, mechanical vibration/shock, current shock, chemical load, high reliable AC, DC breaking ability, with strong current limit, high breaking ability, suitable for energy storage, charging pile and other industry applications. It can be used as short circuit and backup protection for energy storage system, charging pile system, power system and other devices and equipment.

Rated working voltage: AC690V/AC700V, rated working current: 125A ~ 200A, breaking capacity I1:50kA.

1.2、 Structural characteristics

This product is a round pipe bolt connection type fuse. It has the characteristics of small volume, low fusing I²t value, high breaking ability and resistance to current shock. The fuse body is a consumable part, composed of melting tube, melt, filler, etc. The melt is enclosed in a tube filled with high purity quartz sand as an arc extinguishing medium. The two ends of the melt are spot-welded and the end caps form a closed tube structure.

1.3、 Performance and conformance to standards

- Rated voltage: AC690V/AC700V
- Rated current: 125A, 160A, 200A
- Use categories: aR
- Breaking capacity I1: 50kA
- Rated frequency: 45Hz~62Hz
- Performance and environmental reliability refer to IEC 60269.4, ISO8820, GB/T 31465
- Comply with RoHS directive

2、 Product model、

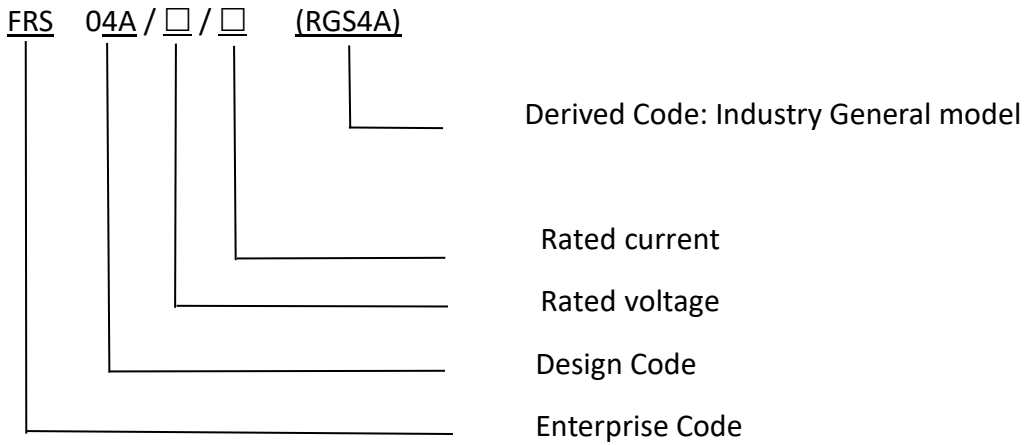

An example of the model number: FRS04A/AC690/125A

Said: Semiconductor Equipment Protection Fuse, FRS04A, rated voltage AC690, rated current: 125A

3、 Shape and installation dimensions

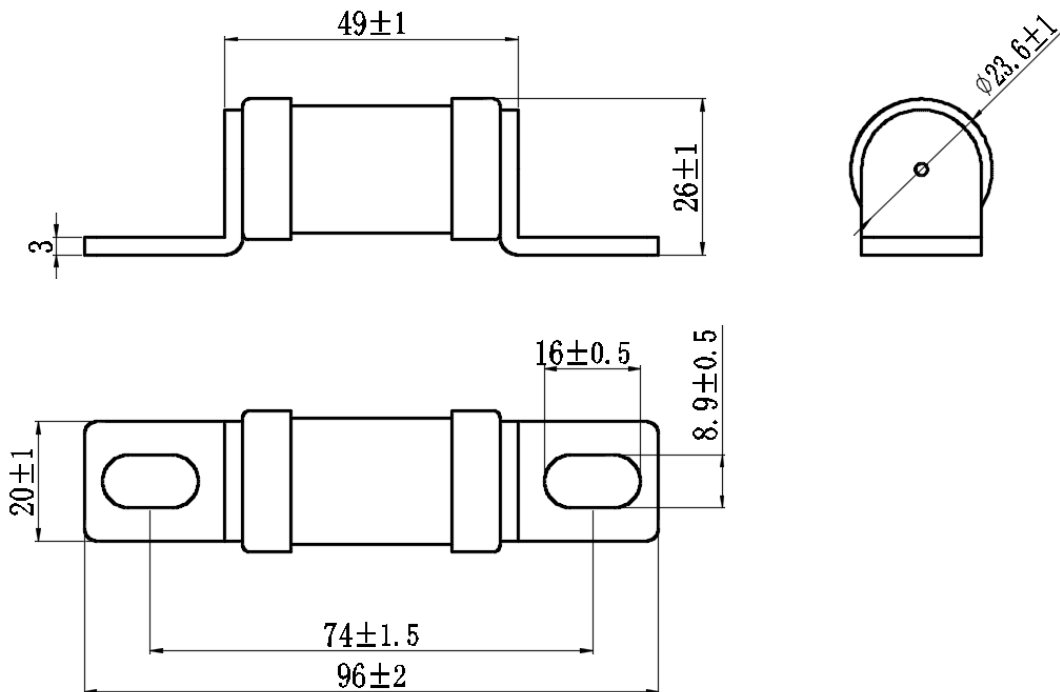

4、 Tightening torque of connecting screw

The tightening torque of the connecting screw is shown in Table 1

Table 1、 tightening torque of wiring screws

Thread	Recommended torque (N.m)
M8	11±1

5、 Main technical parameters

The main technical parameters are shown in Table 2

Table 2. Main technical parameters

Product model	Rated current In (A)	Power consumption (W)		Voltage drop (In、 mV)	I ² t (A ² s) /AC690V/AC700V		Installation	
		1In	0.5In		Pre-arcing	operating	Way	Tighten torque (N.m)
FRS04A	125	20	5	160	6500	17500	M8 Screws	11±1
	160	20	5	125	11000	30000		
	200	24	6	120	18500	48000		

6、 Pre-arc time-expected current curve

FIG. 1、 Forearc time - expected current curve

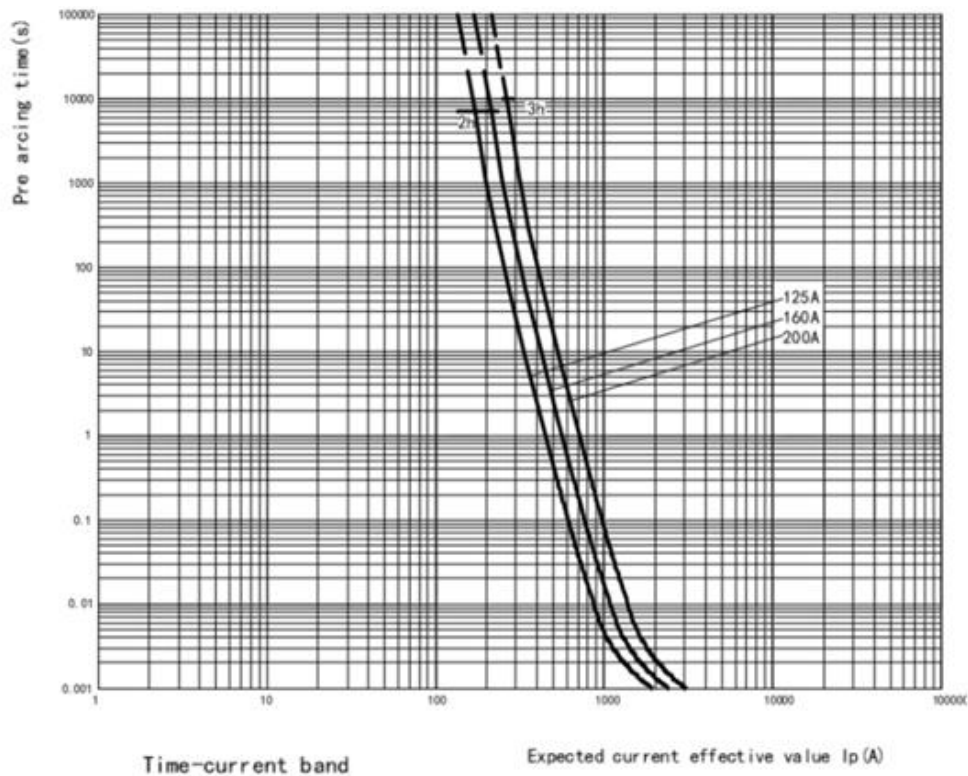

Note:

1. The precision of the characteristic curve is $\pm 15\%$ of the expected current direction error;
2. Small break current: $\geq 5 I_n$
3. Above curve time below 100ms is equivalent time

7、 service conditions

7.1、 Normal working condition and parameter modification

7.1.1、 The fuse works under the following normal operating conditions without additional modification;

7.1.2、 In case of exceeding normal working conditions, if within the range of allowable working conditions, it is necessary to modify some parameters or consult our company; If the scope of work exceeds the allowed, please consult our company, and conduct the required work adaptability assessment and test.

7.1.3、 Recommended long-term current value: $\leq 80\%I_n$ (I_n -- rated current of the fuse)

7.1.4、 Under certain specific conditions, the long-term continuous operating current I of the fuse can be calculated as follows:

$$I = I_n \times K$$

$$K = K_t \times K_s \times K_m \times K_n \times K_v \times K_w$$

Note: K_t 7.2; K_s 7.3; k_m , K_n , K_v , K_w 7.4

7.2、 Ambient air temperature

7.2.1、 Normal working conditions: $-5^\circ\text{C} \sim +40^\circ\text{C}$, and the average temperature within 24 hours does not exceed $+35^\circ\text{C}$;

7.2.2、 Allowed operating conditions: $-40^\circ\text{C} \sim +120^\circ\text{C}$

7.2.3. Correction factor K_t of ambient air temperature change:

Parameter modification of ambient air temperature change: When operating below -5°C , the pre-arc time of low-power overload overcurrent of the fuse is slightly extended, and the rated current is slightly increased. However, unless -5°C is not the working range, generally do not consider increasing the rated current of the fuse.

The fuse works above 40°C , and the rated current requires additional correction, with a correction factor of $-K_t$.

Note 1 : The value of K_t has taken into account the influence of the rated current safety margin of the fuse under normal working conditions.

Note 2 : The ambient air temperature needs to last for more than 1 to 2 hours before it has a significant effect.

7.2.3.1、 When selecting the rated current of the fuse, consider the environment and working conditions, such as: sealing degree, air flow, connecting cable size (length, cross-sectional area, etc.), instantaneous current peak value, etc. The current carrying capacity test of the fuse is carried out at +20°C. In actual use, it is affected by the change of ambient temperature. The higher the ambient temperature is, the higher the working temperature of the fuse is, and the shorter its service life is. Working at lower temperature will prolong the life of the fuse

The modified curve of ambient temperature-load current of the fuse is shown in Figure 2

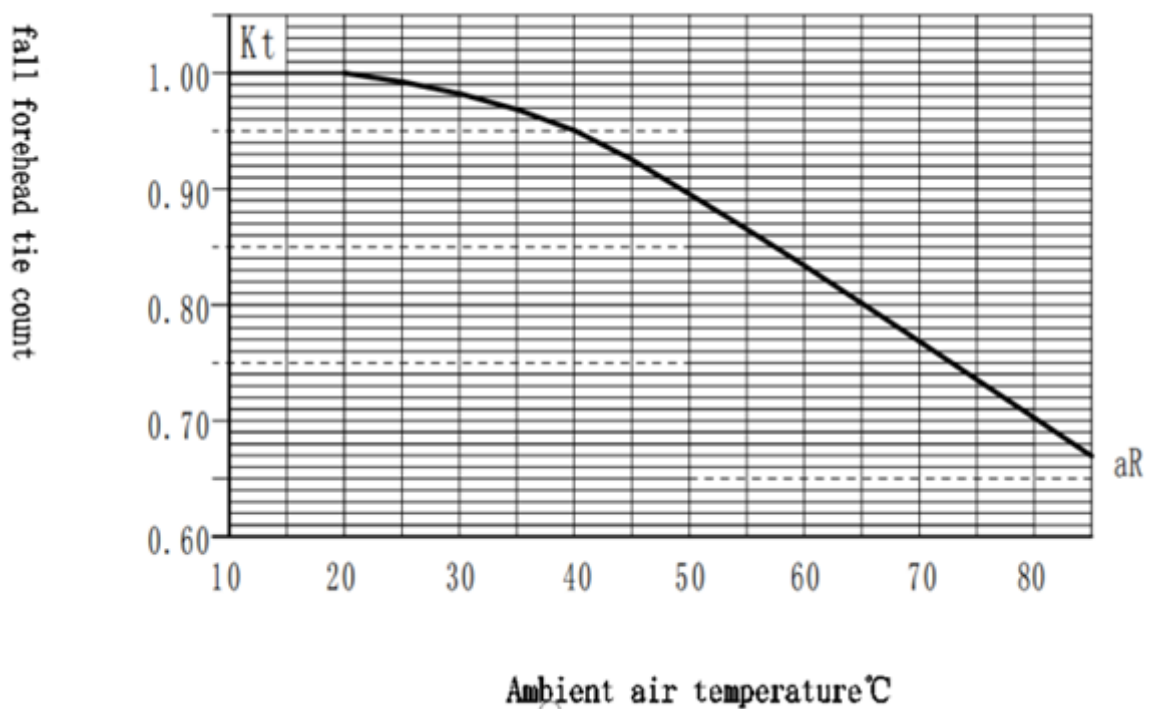

FIG. 2、 Modified curve of ambient temperature-load current of the fuse

7.2.3.2、 For example: the rated current of the FRS04A/AC690/125A fuse is selected In a case where the ambient temperature is 20°C and the rated current of the fuse is $I_n = 125A$, and the working current of the above fuse must be additional reduced when it is applied to the high-temperature environment of +70°C. The modified curve of the ambient temperature-current of the fuse is shown In the figure above: At +70°C, the derating coefficient is 0.78. In order to prevent misoperation of the fuse, the rated current value of the fuse should be re-selected:

$$I_e = 125A / 0.78 = 160A \text{ , According to the standard current level of the fuse: } I_n = 160A$$

7.3、 Elevation:

7.3.1、 Normal working conditions: elevation not more than 2 000m;

7.3.2、 Allowable working conditions: $\leq 5\ 000m$;

7.3.3、 Parameter correction of altitude change (2 000m-5 000m):The altitude mainly brings about the deterioration of insulation, the deterioration of heat dissipation conditions and the change of atmospheric pressure.

7.3.3.1、 fuse temperature rise、 average ambient temperature、 The capacitance reduction factor K_s of the rated current I_n is shown in Table 3

Table 3. Temperature rise of fuse body, mean ambient temperature, capacitance reduction coefficient K_S of rated current I_n

project	Temperature rise of fuse (K)	Mean ambient emperature (°C)	Capacitance reduction coefficient K_S of rated current I_n
Every 100m increase in elevation	+0.5	-0.5	-
Every 1000m increase in elevation	-	-	0.95-0.98

7.3.3.2、 See Table 4 for the multiplication coefficient of normal air pressure and electrical clearance of the fuse.

Table 4、 Multiplication coefficient of normal air pressure and electrical clearance of the fuse

Elevation m	Normal atmospheric pressure kPa	Multiplication coefficient of electrical clearance
2 000	80.0	1.00
3 000	70.0	1.14
4 000	62.0	1.29
5 000	54.0	1.48

Note: the insulation clearance between the fuse and other charged structures, as well as the ground, shall be taken into account by the user.

7.4、 Installation condition

7.4.1、 The fuse body is installed separately in the natural air without ventilation, and there is no other heating or cooling parts within 1m except for the connecting wire.

7.4.2、 The connection terminals of the fuse must be stable and reliable. Contact resistance should not significantly affect the operation of the fuse.

7.4.3、 The fuse can be installed vertically, horizontally or tilted. If the spring pressure is used to ensure the electrical connection fuse, install the fuse in a proper position to avoid the adverse effects of gravity and vibration on the electrical connection.

7.4.4. The fuses have a significant effect on the cross-section of the connecting wire, km-the correction factor for the cross-section of the connecting wire.

The copper wire section for normal operating conditions as defined by IEC 60269 is shown in table 5 below (current is the standard value for long-term persistent RMS):

Table 5、 Section area of standard connecting copper wire

Rated current (A)	Connect the wires (mm ²)
125	50
160	70
200	95

The Km is shown in Figure 3. The ratio of applied traverse area to standard area is between 80% and 120%:

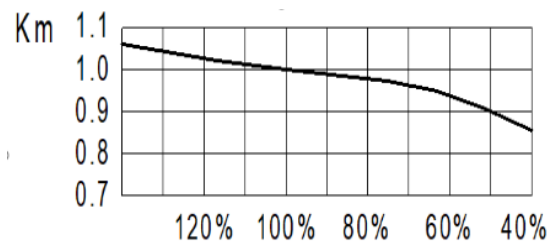

Connection wire cross section/Standard cross section

Fig. 3、 Km-connection section area correction coefficient

7.4.5、 To be installed in an open or enclosed box (case): because there are many kinds of box (shell) body, the influence degree of fuse is not consistent, so it is difficult to use general correction coefficient. It is recommended to test the working temperature rise or temperature of the fuse to determine the long-term working reliability under the application conditions. This test can be used to verify that the correction factor of the rated current is appropriate. In all types of service conditions, including the open or closed box, the fuse can withstand conditions can refer to the following:

"g" class, long-term continuous operation, terminal temperature can allow 110(100)°C or higher. 130°C for short-time work. It should be noted that the above conditions may not be appropriate for a particular fuse and the manufacturer should be consulted or the product description should be consulted. Any state, the fuse long-term continuous work needs the structure intact, performance degradation or aging without cumulative impact of the state.

7.4.6、 Multiple fuses (including other heating parts) installed in the same box,

Kn - correction factor of arrangement quantity

It is not suitable to give a general correction coefficient due to the influence of many factors, such as the difference of box body, the difference of installation mode, the difference of interval distance and the difference of air flow. If the heat effect between multiple heating components is mainly through air conduction, it can be reduced to the influence of ambient air temperature, without additional correction.

Kn refer to table 6 if multiple fuses working independently are closely packed.

Table 6. Kn-arrangement number correction factor:

Arrangement	The juxtaposition of air between the flow of cooling is significantly limited			Notes
Number of arrangements	4-9	10-18	19-36	In the same box There is no significant interval in the same row The box body is not airtight
Kn	0.98~0.96	0.94~0.96	0.92~0.94	

7.4.7、 Increased cooling:

Common measures to enhance cooling: forced air-cooled, one-sided water-cooled, double-sided water-cooled fuse will significantly increase the rated current.

Reference to the specific product specifications of the correction factor.

7.4.7.1、 Forced Air Cooling:

Forced air cooling can increase the heat dissipation of the fuse, increase the rated current of the fuse, and the cooling effect is affected by the wind speed, air flow angle, heat dissipation area, heat dissipation power and the structure parameters of the fuse. Correction Factor for wind speed and rated current- K_v as shown in Figure 4.

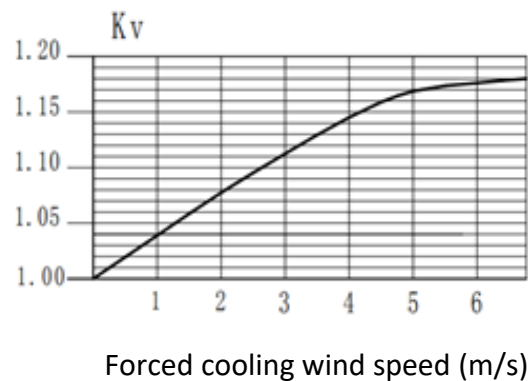

FIG. 4、 correction coefficient of wind speed and rated current – K_v

7.4.7.2、 single/double water (liquid) cooling:

The effect of single-side/double-side water (liquid) cooling is influenced by the area of water-cooled mother row, inlet and outlet water temperature, heat dissipation power and the structure parameters of fuses. The correction coefficient is different, $k_w = 1.01 \sim 1.12$.

7.5、 Great atmospheric conditions

7.5.1、 Normal operating conditions

- 、 The air is clean and its relative humidity does not exceed 50% at the highest temperature of 40°C
- 、 Higher relative humidity can be found at lower temperatures, for example, 90% at 20°C
- 、 Under these conditions, moderate condensation may occasionally occur due to temperature changes

7.5.2、 Permissible working conditions

When there is no obvious condensation, the relative humidity can reach 95%.

7.6、 Vibration environment and ability to withstand earthquake and other disasters

7.6.1、 This series of fuses have good resistance to vibration and impact, and can withstand more than 10g acceleration.

7.6.2、 For other application environments with strong vibration, please consult our technical department, which will generally be tested and verified

8、 Safe use and maintenance

8.1、 When the fuse is installed, the minimum gap between the live parts of the two adjacent fuses shall meet the insulation requirements. If necessary, insulation partitions shall be installed between the fuses to prevent, Interphase short circuit is caused when the fuse is replaced with power.

8.2、 Combined with regular maintenance of electrical equipment, check and maintain, remove dust, oxidation layer in contact with conductive parts, etc.

8.3、 The fuse with mechanical damage must be replaced.

8.4、 Do not replace the fuse with load unless permitted by use requirements, such as fuse type load switches